

PLAN VIEW

**INSPECTION BOX
(OPTIONAL)**

NOTE:
ACCESS MANHOLES WITH A MINIMUM DIAMETER OF 24" SHALL BE PROVIDED OVER EACH GREASE INTERCEPTOR CHAMBER. THE ACCESS MANHOLE SHALL EXTEND AT LEAST TO FINISHED GRADE AND BE DESIGNED AND MAINTAINED TO PREVENT WATER INFLOW OR INFILTRATION. THE MANHOLES SHALL HAVE READILY REMOVABLE COVERS TO FACILITATE INSPECTION, GREASE REMOVAL, AND WASTEWATER SAMPLING ACTIVITIES.

ASTM D-65 OR CONSEAL
WORKABILITY TEMP
30 TO 300 DEGREES F.

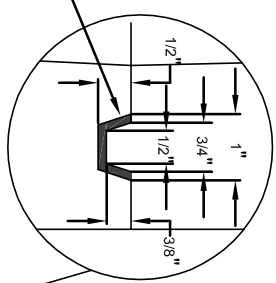

JOINT DETAIL

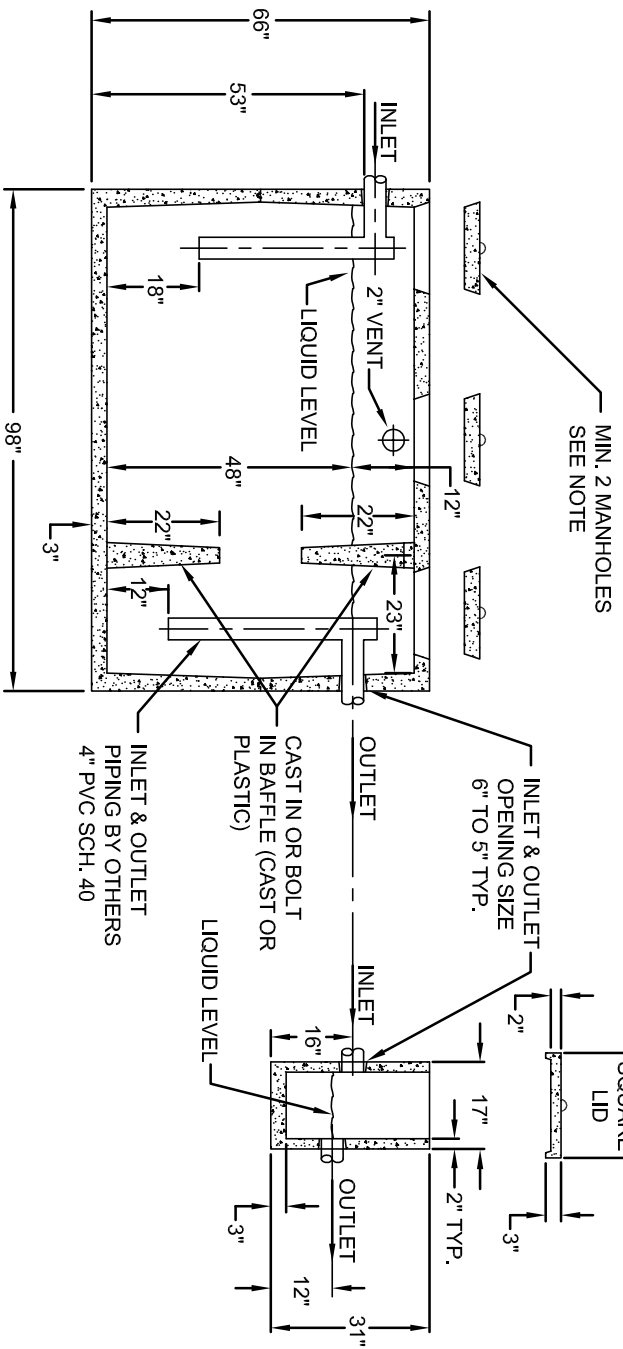

SECTION A-A

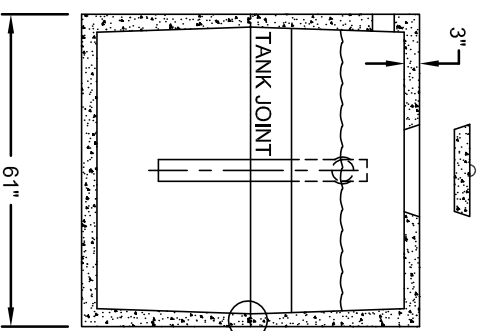

SECTION B-B

**GREASE INTERCEPTOR
1,000 GAL. CAPACITY
W/ OPTIONAL INSPECTION BOX**



BUTLER COUNTY DEPARTMENT OF ENVIRONMENTAL SERVICES

130 HIGH STREET
HAMILTON, OH 45011
TELEPHONE: 513-887-3066
FAX: 513-887-3777